

MANUAL

CARAVAN

RM 4270
RM 4271

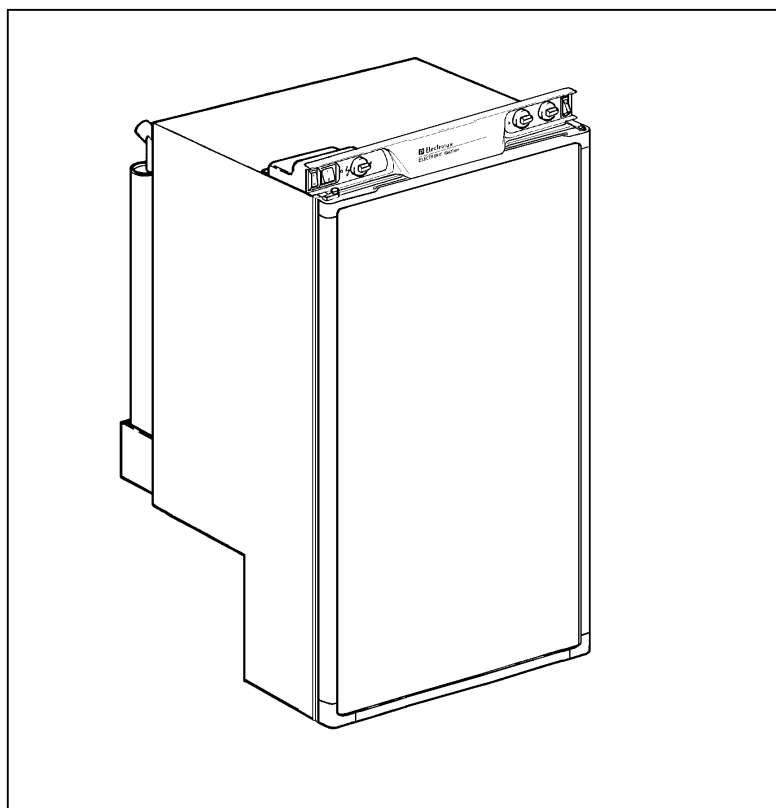

Deutsch	Seite	1	Svenska	sida	31
English	page	7	Dansk	side	37
Français	page	13	Norsk	side	43
Italiano	pagina	19	Nederlands	pag.	49
Español	pagina	25	Suomi	sivu	55
			Português	cara	61

OPERATING AND INSTALLATION INSTRUCTIONS FOR ELECTROLUX REFRIGERATORS

INTRODUCTION

We are pleased that you have chosen this refrigerator and hope you will derive much satisfaction from using it, but first a few well-meant words of advice:

It is important to read through these instructions carefully before using the refrigerator.

To ensure good refrigeration and economical operation, the refrigerator must be installed and used as described in these instructions.

The refrigerator is designed for building-in to leisure vehicles such as caravans or motorhomes.

The appliance is certified according to the EU-Gas-Directive 90/396/EEC.

TRANSIT DAMAGE

Inspect the refrigerator for damage. Transit damage must be reported to whoever is responsible for delivery not later than seven days after the refrigerator was delivered.

DATA PLATE

Check the data plate, inside the refrigerator, to ensure that you have received the right model.

The right gas pressure is 30 mbar.

The right voltage is 230 volts.

The data plate contains e. g. the following details:

Model designation RM

Product number

Serial number

Since these details will be needed if you have to contact service personnel, it is a good idea to make a note of them here.

CONTENTS

OPERATING INSTRUCTIONS	8
CONTROLS	8
STARTING THE REFRIGERATOR	8
WINTER OPERATION	8
REGULATING THE TEMPERATURE.....	8
TRAVEL CATCH.....	9
FOOD STORAGE	9
ICE-MAKING	9
DEFROSTING.....	9
CLEANING THE REFRIGERATOR	9
TURNING OFF THE REFRIGERATOR	9
IF THE `FRIDGE FAILS TO WORK.....	9
MAINTENANCE.....	10
SOME USEFUL HINTS	10
GUARANTEE AND SERVICE.....	10
TECHNICAL DATA	10
INSTALLATION INSTRUCTIONS	10
REPOSITIONING THE HINGES	10
DOOR PANEL.....	10
BUILDING-IN.....	11
VENTILATION OF THE UNIT	11
LP GAS CONNECTION.....	11
ELECTRICAL CONNECTION.....	12

OPERATING INSTRUCTIONS

CONTROLS

The refrigerator can be run on either 230 V, 12 V or LP gas. Changing between these modes of operation is carried out by means of the controls of the control panel shown in fig 3.

Two rocker switches are used to select the electric power supply, one for 230 V (B) and one for 12 V (A).

Refrigerator temperature is controlled by a thermostat (C) when the unit runs on 230 V. The gas supply is turned on/off by means of the knob (D). When lighting the gas, one must press in the knob as explained further on.

Refrigerator temperature is controlled by a thermostat (E) when the refrigerator runs on LP gas. Please note that the thermostat has no "off" position.

In model **RM 4271**, the gas flame is electronically lit, monitored and relit if necessary. For this the toggle switch (F) should be "on" during gas operation.

An indicator lamp in the switch flashes when the automatic igniter attempts to light the burner. Otherwise this lamp is off.

In model **RM 4270** a manual piezo-electric igniter is used. When the button (G) is pressed, sparks are generated at the burner.

Inside the refrigerator at bottom left is a sight glass for the burner. A blue light can be seen through it when the flame is alight. (**RM 4270**)

STARTING THE REFRIGERATOR

Caution!

Only use one source of energy at a time

The position numbers refer to fig. 3.

LP Gas operation

After initial installation, servicing, or changing gas cylinders etc., the gas pipes may contain some air which should be allowed to escape by briefly turning on the refrigerator or other appliances. This will ensure that the flame lights immediately.

To start gas operation:

1. Open the shut-off valve of the gas bottle (check that there is enough gas). Open any on-board shut-off valve.
2. Check that the switches for mains and 12 V operation are off.

If you have Model **RM 4271** proceed as follows:

3. Turn on the gas supply by pressing the (D) knob and turning it to the position 
4. Set the thermostat knob (E) to the highest setting.
5. Depress switch (F). A light in the switch should now start to flash, indicating that sparks are being generated at the burner.
6. Press the (D) button. This opens the flame failure device and allows gas to flow to the burner.
7. When the flame lights, the sparking stops automatically and the switch stops flashing.

8. Keep the (D) button pressed for a further 10 to 15 seconds to activate the flame failure device, then release it.

If you have Model **RM 4270** proceed as follows:

3. Turn on the gas supply by pressing the (D) knob and turning it to the position 
4. Set the thermostat knob (E) to the highest setting.
5. Keeping the flame failure device button (D) pressed, operate the igniter (G) until the flame lights.
6. Keep the (D) button pressed for a further 10 to 15 seconds then release it.

The flame can be observed in a viewing glass inside the refrigerator at the bottom left (**RM4270**).

To terminate gas operation, turn knob (D) to "●" and (when applicable) set switch (F) to "0".

230 V Operation

- Turn off gas or 12 V operation when applicable.
- Turn the knob (C) of the thermostat to its highest (coldest) position.
- Set switch (B) to position I. The switch will light up green when the power supply is connected.

12 V Operation

Only operate your refrigerator on 12 V when the engine of the vehicle is running - otherwise your battery will soon be discharged.

- If applicable, turn off the gas operation.
- Set the 12 V rocker switch (A) to I. The switch will light up red when the power supply is connected.

WINTER OPERATION

Please check that the ventilation grilles or the flue outlet are not blocked by snow, leaves etc.

ELECTROLUX ventilation grilles **A 1620** (fig 2), can be fitted with winter covers, model **WA 120**, to protect the cooling unit against cold air. The covers may be fitted when the outside temperature is below approx. 10°C and should be fitted when the temperature is below the freezing point.

We suggest that you fit the winter covers also in the case that the vehicle is laid up during the winter months.

REGULATING THE TEMPERATURE

The position number refers to fig. 3.

It will take a few hours for the refrigerator to reach normal operating temperature. So we suggest you start it well in advance of a trip and if possible store it with precooled foodstuffs.

On 230 V operation the refrigerator is controlled by a thermostat and the thermostat knob (C) should be set at 3-5. If a lower (colder) temperature is desired, set the thermostat to a higher figure.

On 12 V operation the refrigerator works continuously.

On LP gas operation the refrigerator temperature is regulated by the gas thermostat (E), which should be set at 3-5. If a lower (colder) temperature is desired, set the thermostat to a higher figure.

TRAVEL CATCH

Make sure that the travel catch is engaged when the caravan is on the move, (fig 1).

The travel catch at the top of the door can be set in two different positions. In one position the door is held tightly shut. In the other position the door is secured ajar so that the refrigerator can be aired when not in use.

FOOD STORAGE

Always keep food in closed containers. Never put hot food in the refrigerator; allow it to cool first.

Never keep items in the refrigerator which might give off flammable gases.

The 2-star (★★) frozen food compartment is intended for the storage of frozen food and for making ice. It is not suitable for freezing items of food.

Never put bottles or cans of fizzy drinks in the frozen food storage compartment as they may burst when freezing. Also don't give children ice lollies straight from the frozen food as they could cause frost burns.

Most kinds of frozen food can be stored in the frozen food compartment for about a month. This period of time may vary, however, and it is important to follow the instructions on the individual packets.

ICE MAKING

It is practical to make ice during the night - then the refrigerator is less demanded and the cooling unit has more reserves. Fill the ice tray to just below the brim with drinking water and place it on the freezer shelf.

To speed up the ice making, one can spill one or two spoonfuls of water on the freezer shelf to improve the contact to the ice tray. If you have more than one ice tray it is a good idea to make ice in advance and save the frozen trays in the frozen food compartment.

DEFROSTING

Frost will gradually accumulate on the refrigerating surfaces. It must not be allowed to grow too thick as it acts as an insulator and adversely affects refrigerator performance.

Check the formation of frost regularly every week and when it gets about 3 mm thick, defrost the refrigerator.

To defrost the `fridge, turn it off and remove the ice tray and all food items. **Warning:** normally the temperature of items of frozen foods would rise unduly during defrosting and so they should be consumed within 24 h or discarded.

Do not try to accelerate defrosting by using any kind of heating appliance, as this might damage the plastic surfaces of the refrigerator. Neither should any sharp objects be used to scrape off the ice.

The defrost water runs from a collector channel to a receptacle at the rear of the refrigerator where it evaporates. Defrost water in the freezer compartment should be mopped up with a cloth.

When the ice has melted, wipe the refrigerator dry and restart it. Place the food items back inside but wait until the refrigerator is cold before making ice cubes.

CLEANING THE REFRIGERATOR

Clean the inside of the refrigerator regularly to keep it fresh and hygienic.

Soak a cloth in a solution consisting of a teaspoon of bicarbonate of soda to half a litre of warm water. Wring out the cloth and use it to clean the interior of the refrigerator and its fittings.

Never use detergents, scouring powder, strongly scented products or wax polish to clean the interior of the refrigerator as they may damage the surfaces and leave a strong odour.

The exterior of the refrigerator should be wiped clean now and again, using a damp cloth and a small quantity of detergent. But not the door gasket, which should only be cleaned with soap and water and then thoroughly dried.

TURNING OFF THE REFRIGERATOR

If the refrigerator is not to be used for some time:

1. Set any switches to 0.
2. Set the gas valve (D) to ●.
3. Shut off any on-board valve in the gas line to the refrigerator.
4. Empty the refrigerator. Defrost and clean it as described earlier. Leave the doors of the refrigerator and the frozen food compartment ajar. Use the travel catch to hold in this position.
5. When the vehicle is laid up for a long period of time (e.g. during the winter months), we suggest fitting the winter covers **WA 120**, fig. 2, onto the vent grills.

IF THE `FRIDGE FAILS TO WORK

Check the following points before calling a service technician:

1. That the **STARTING THE REFRIGERATOR** instructions have been followed.
2. The refrigerator is level.
3. If it is possible to start the refrigerator on any of the connected sources of energy.
4. If the refrigerator fails to work on gas, check:
 - That the gas bottle is not empty.
 - That all LP-gas valves are open.
5. If the refrigerator fails to work on 12 V, check:
 - That the 12 V supply is connected to the refrigerator.
 - That the fuse on the 12 V supply is intact.
 - That the 12 V switch is on.
6. If the refrigerator fails to work on 230 V, check:
 - That the 230 V supply is connected to the refrigerator.
 - That the fuse is intact.

If the refrigerator is not cold enough it may be because:

1. The ventilation is inadequate owing to reduced area of the ventilation passages (partial blockage of grilles from wire mesh etc).

2. The evaporator is frosted up.
3. The temperature control setting is incorrect.
4. The gas pressure is incorrect - check the pressure regulator at the gas container.
5. The ambient temperature is too high.
6. Too much food is loaded at one time.
7. The door is not properly closed or the magnetic sealing strip is defective.
8. More than one source of energy is used at the same time. If the refrigerator still does not work properly, call a service technician.

The sealed cooling system must not be opened, since it is under high pressure.

MAINTENANCE

Concerning gas- and electric installations, only authorized experts are allowed to carry out maintenance and repair works. Besides, it is recommendable to contact an authorized service if it comes to repair works.

According to the valid regulations G607 of DVGW, the gas installation as well as the connect flue outlets are to be checked every two years by an expert (this has to be arranged by the person responsible).

SOME USEFUL HINTS

Make sure that:

- The refrigerator is not operating on 12 V when the vehicle is parked, otherwise you will drain the car battery in a short time.
- Defrosting is carried out periodically.
- The refrigerator is left with the door(s) ajar when it is not to be used for some time.
- Liquids or items with a strong odour are well packaged.
- The ventilation openings are unobstructed.
- The door is secured by means of the travel catch when the caravan is on the move.
- Only one mode of operation at a time is used to run the refrigerator.

GUARANTEE AND SERVICE

The refrigerator is guaranteed for one full year on condition that it is used in a correct manner and in accordance with these operating and installation instructions.

It is also embraced by a European guarantee as described in the brochure supplied with the refrigerator.

Service and spare parts are obtainable from your dealer or Electrolux - consult the telephone directory

TECHNICAL DATA RM 4270/ 71

Overall dimensions, refrigerator

Height	821 mm
Width	486 mm
Depth (incl. cooling unit)	
without door.....	495 mm
with door.....	534 mm

Build-in dimensions

Height	825 mm
Width	490 mm
Depth	505 mm
Step (wheel house)	
Height	max 220 mm
Width.....	490 mm
Depth.....	max 225 mm

Capacity

gross	77 lit.
net	72 lit.
frozen food compt	7 lit.

Weight (without packaging) 23 kg

Electrical data

Input 230 V	125 watt
12 V	120 watt
Energy consumption /24 h.	2,5 kWh

LP gas data

Input	232 watt
ditto, low flame	105 watt
Energy consumption /24 h.	0,27 kg

Cooling medium Ammonia (R 717)

INSTALLATION INSTRUCTIONS

REPOSITIONING THE HINGES

The door hinges can be moved to the opposite side in the following way:

- Unscrew the upper hinge pin, taking care not to lose the set of washers and bushes.
- Lift the door from the lower hinge pin.
- Unscrew the pin and mount it on the opposite side hinge.
- Unscrew the travel catch and mount it on the opposite side.
- On the upper edge of the door are two plastic inserts for the alternative holes of the travel catch. Pry out carefully and exchange
- Fit the door on the pin and reassemble the pin with washers and bushes in its new place.
- Check that the door closes properly and seals all round.

DOOR PANEL

The door panel can easily be mounted or changed. The dimensions of the panel must be:

Height	740 mm
Width	453,5 mm
Thickness	max 3,8 mm

- Remove the door, see REPOSITIONING THE HINGES.

- Remove the lower trim moulding and then withdraw the panel by sliding it downwards.
- Fit new panel in place and slide it up as far as possible.
- Fit the trim moulding back in place.

BUILDING-IN

The refrigerator is intended for installation in a caravan or motorhome, and the description relates to this application.

The refrigerator must not be exposed to radiated heat from hot objects (e.g. below a cooker without proper heat shielding).

Excessive heat irradiation impairs performance and leads to increased energy consumption. For this reason the refrigerator should be installed if possible not at the entrance side of the vehicle - normally orientated south and often with an awning - which would impair the dispersion of heat and combustion gases from the ventilation openings.

It is not a good practice to install the refrigerator so that the vent openings are covered by the vehicle's entrance door when this is open. This would reduce the ventilation air flow to the cooling unit and reduce refrigeration performance.

The enclosure

The refrigerator must be installed in an enclosure, the dimensions of which are shown in **TECHNICAL DATA**.

The bottom of the enclosure must be horizontal and even so that the refrigerator can be easily pushed into place. It must be sturdy enough to carry the weight of the refrigerator.

Battens must be installed at the enclosure and fitted with sealing strips, as shown in fig. 4.

Slide in the refrigerator until it is flush with the front of the recess. There must be 10-20 mm free space behind the refrigerator.

Four fasteners are fitted in plastic bushings in the side walls of the fridge, fig. 7. They are used for securing the refrigerator in the enclosure.

The side walls of the enclosure and/or any wooden braces installed to hold the refrigerator must be dimensioned to seat the screws securely, also considering the forces due to the movement of the vehicle.

With the refrigerator in place, drive the screws through the bushings in the lining of the refrigerator into the walls of the enclosure (fig.7). There must not be more than 3mm of clearance between refrigerator and enclosure on each side. If necessary, wooden strips or similar should be fitted.

Note: This is the only approved means of securing the refrigerator to the enclosure and to the vehicle. Fasteners penetrating other parts of the insulation (PU) foam of the refrigerator might damage components like electric wiring etc.

VENTILATION OF THE UNIT

At high ambient temperatures the refrigeration unit will only perform adequately when properly ventilated.

The refrigeration unit is ventilated via two openings in the wall of the caravan (see fig. 5). Fresh air enters through the lower opening and warm air is discharged through the upper one.

Locate the lower opening immediately above the floor of the recess, and the upper one as high as possible above the condenser (C) of the refrigeration unit, at least as shown in fig. 6b but preferably as shown in fig. 6a.

Ventilation grilles Fig. 2

The openings in the caravan wall must be fitted with the **Electrolux** ventilation systems.

Fitting the grilles, model **A 1620**, which were specially developed by Electrolux for this purpose (shown as D in fig. 6). It is a good idea, to install the frame **R 1640** (A in the same figure), at the same time. Then the grilles can be easily removed which permits inspection and small repairs to be carried out without the necessity for removing the refrigerator from the recess.

If there is no outer grille at floor level where leaking gas can escape, a 40 mm hole to the outside should be made in the floor of the recess to drain any unburnt gas to the outside gas.

Fit the hole with wire mesh and an angled plate to protect from stones, mud etc.

Removal of flue gases

The ventilation passage at the rear of the recess, between the outer wall of the vehicle and the refrigerator (fig. 6), is sealed off against the living space, and so cold draughts are excluded (winter camping) and no flue gases can penetrate into the vehicle. Thus a special flue outlet is no longer necessary - the gases are dispersed through the upper vent grille.

Note: With this mode of installation the same type of grilles (without an integrated flue outlet), should be installed at the upper as well as at the lower vent opening. The angled T-piece for the flue tube (when delivered) should not be used in this case.

The top of the enclosure above the flue tube (I), fig. 6, should be covered with aluminum sheet metal, as indicated in (B), to facilitate the heat dispersion.

In fig. 6 the letters have the following meaning:

- A. Frame **R 1640** for the grilles
- B. Aluminum cladding
- C. Condenser of cooling unit
- D. Vent grill **A 1620**
- E. Sealing profile (optional extra)
Width 486 mm, Electrolux art. nr. 295 1147-10
- F. Refrigerator rear wall
- G. Wooden batten approx. 10 x 20 mm (see fig. 4)
- H. Height of the enclosure (see **TECHNICAL DATA**)
- I. Flue tube

LP GAS CONNECTION

CAUTION! CHECK THAT THE GAS SUPPLIED TO THE REFRIGERATOR IS AT THE CORRECT PRESSURE. SEE THE REDUCING VALVE ON THE LP GAS CONTAINER

The refrigerator is designed for operation on LP gas of Butane type the pressure of which must be 28 mbar for Butane and 37 mbar for Propane.

Check that this is stated on the data plate. The refrigerator is not designed for operation on town gas or natural gas.

The gas installation should only be carried out by an authorized gas fitter.

The supply pipe should preferably be of copper. If any other material is used, it must be of a type approved for use with continuously operating bottled- gas appliances, and have threaded compression connections throughout. **PUSH-ON CONNECTIONS MUST NOT BE USED** (We do not approve the use of "rubber" type flexible tubing for connecting permanently operating appliances of this type in the United Kingdom). All connectors etc. should be of a type specifically designed for the type and diameter of the connection pipe used, and screwed joints should be sealed with a joining compound approved for use with bottled gas.

The gas supply pipe should be connected to the gas inlet pipe on the right hand side of the gas control valve by means of a suitable threaded compression coupling.

In making the connection to the refrigerator, a gas cock of an approved type for use on LPG must be incorporated in the supply line in a position which is readily accessible to the user. For eventual servicing purposes, the union should be on the outlet side of the cock and the pipework should be positioned so as not to prevent the refrigerator from being readily withdrawn.

ELECTRICAL CONNECTION

The electrical installation must be carried out in a proper and durable manner, taking into account all relevant regulations and codes of practice. For mains voltage operation, it is important that the circuit to and in the caravan is effectively earthed. **ALL MAINS VOLTAGE WIRING IN THE CARAVAN MUST BE INSTALLED IN ACCORDANCE WITH CURRENT I.E.E. REGULATIONS INCLUDING THE USE OF AN OUTLET AND COUPLER TO BS4343/-CEE17.**

For connection to a 230 V electricity supply, the refrigerator has a 3-core mains lead which is intended for connection to a properly earthed plug and socket outlet or fused spur.

IMPORTANT: The wires in the mains lead of this appliance are coloured in accordance with the following code:

GREEN-AND-YELLOW = EARTH

BLUE = NEUTRAL

BROWN = LIVE

As the colours of the wires may not correspond with the coloured markings identifying the terminals in your plug, in the United Kingdom, proceed as follows:

The wire which is coloured **GREEN-AND-YELLOW** must be connected to the terminal in the plug which is marked with the letter E or by the earth symbol  or coloured green or green-and-yellow.

The wire which is coloured **BLUE** must be connected to the terminal which is marked with the letter N or coloured black.

The wire which is coloured **BROWN** must be connected to the terminal which is marked with the letter L or coloured red.

WARNING! THIS APPLIANCE MUST BE EARTHED !

In the United Kingdom, the plug or circuit to the refrigerator must be fitted with a fuse not greater than 5 amps. If a 13 amp.(B.S.1363) fused plug is used, it should be fitted with a

3 amp. fuse. In other countries, the fuse rating will depend upon the voltage and local practice.

230 V Supplies.

Check that the voltage stated on the data plate is the same as the mains voltage in use (230 V).

Electrical leads must be routed and secured so that they cannot come into contact with hot or sharp parts of the refrigerator.

12 V Supplies

Connect the refrigerator to the vehicle battery by a direct cable. To avoid a voltage drop, the cross sectional area of the connecting cable between battery and refrigerator must be at least 2.5 mm² if the distance is less than 9 meters, and at least 4 mm² if the distance is more than 9 meters

To ensure satisfactory operation, the positive lead must be fitted with a fuse rated at max. 16 A.

To prevent the refrigerator from draining the battery, make sure that the current supplied to the caravan is cut off when the vehicle engine is not running, for example by fitting an ignition control relay.

Diagramme for the mains installation: fig. 9

Diagramme for the 12 V installation:

fig. 10 (RM 4270), fig. 12 (RM 4271)

The notations in the wiring diagramme are:

- A. Electronic igniter/reigniter
- B. Electrode (at burner)
- C. 12 V heating element
- D. Switch for 12 V operation
- E. Switch for reigniter (gas op.)
- F. Electric thermostat
- G. Heating element, 230 V
- H. Switch for 230 V operation
- J. Terminal block
- L. Terminal block

12 V supply of reigniter (RM 4271)

Fig. 12 shows the wiring diagramme of the refrigerator as delivered. The 12 V supply enters at (L). The reigniter (A) is fed via two wires (1) and (2) at terminal block (L).

It is advisable to feed the reigniter and the lighting from a separate 12 V source. To do this: remove the wires (1) and (2) and connect the supply as is shown in fig. 11.

In some executions there is an extra terminal block (J), of fig. 12. In this case one disconnects the wires as said above but connects the separate supply to (J).

The reigniter should not be connected directly to a battery charger but only over a battery.

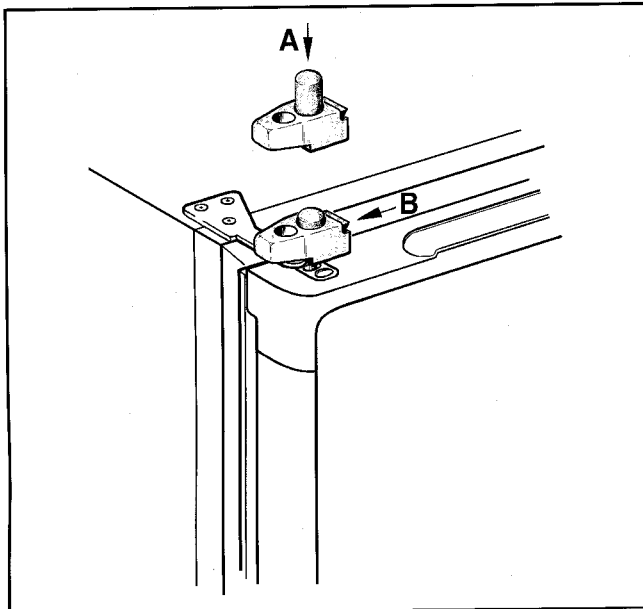

Fig. 1

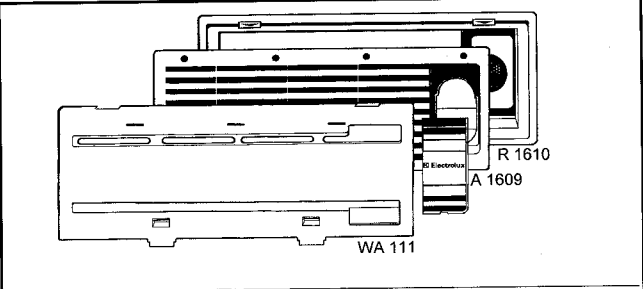

Fig. 2

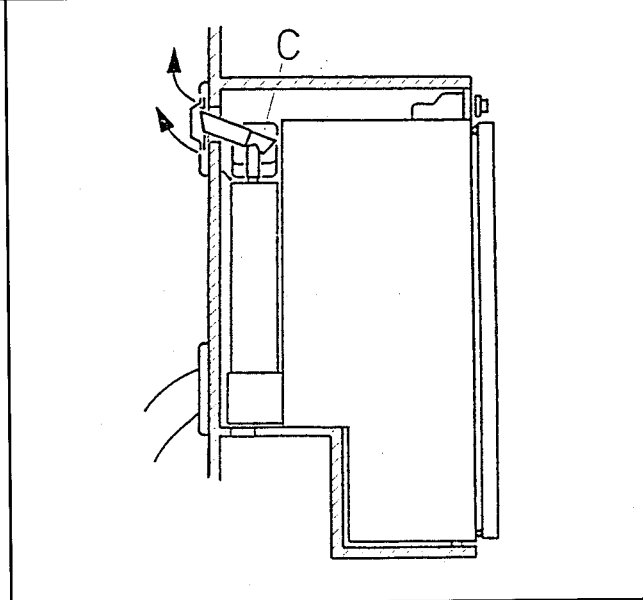
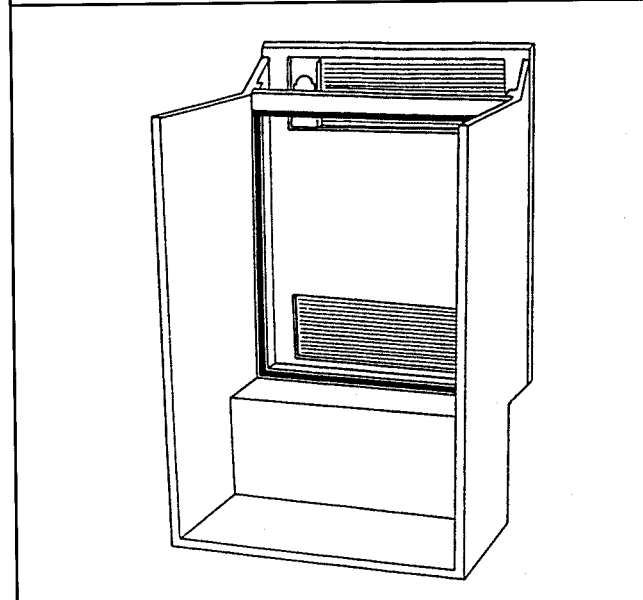
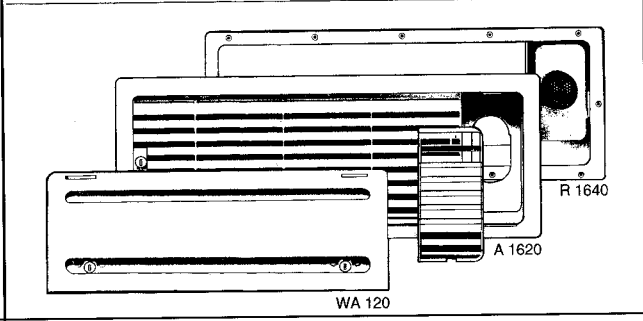

Fig. 4

Fig. 5

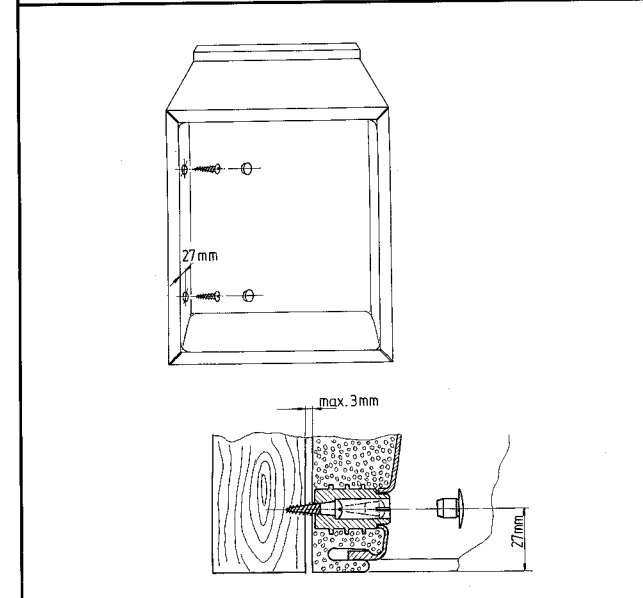

Fig. 6

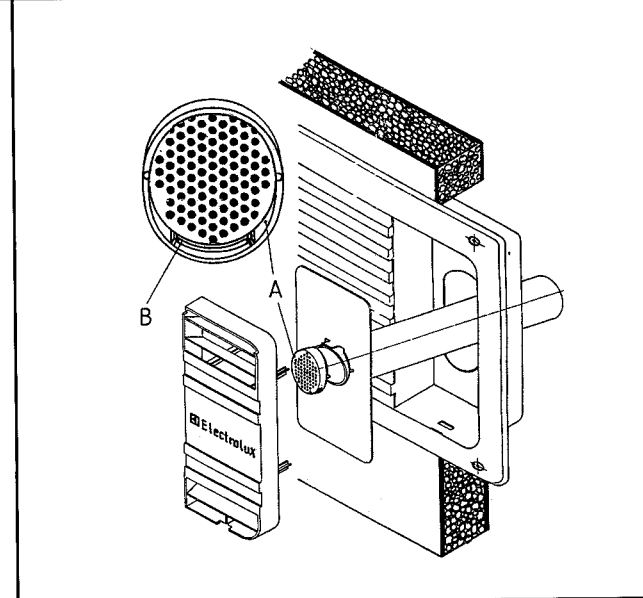

Fig. 7

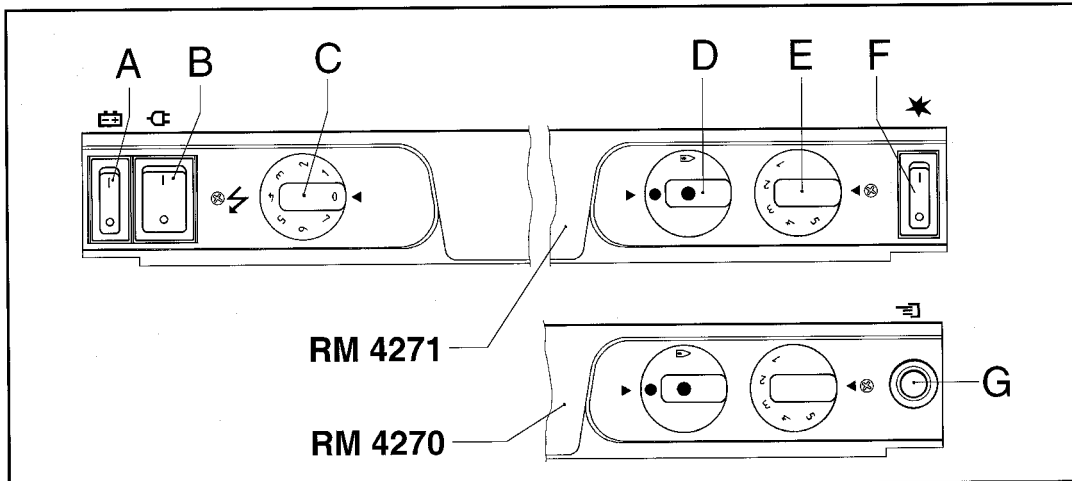

Fig. 3

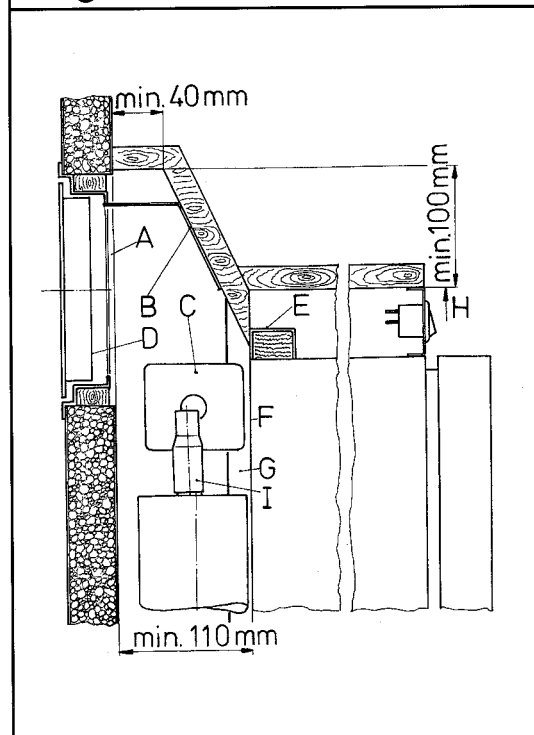

Fig. 6a

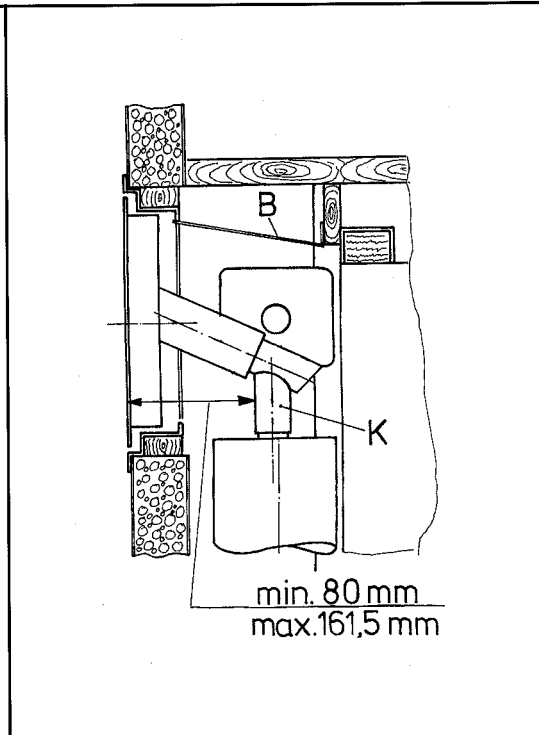

Fig. 6b

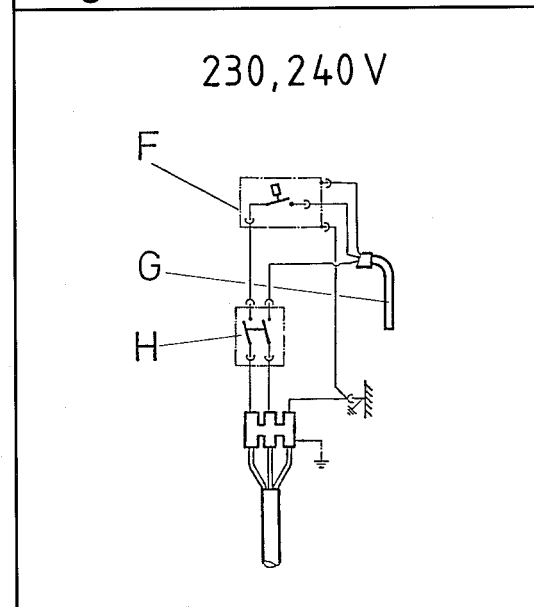

Fig. 9

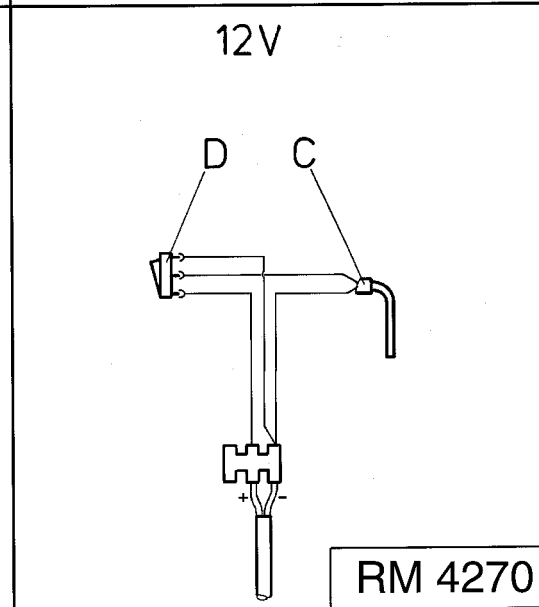
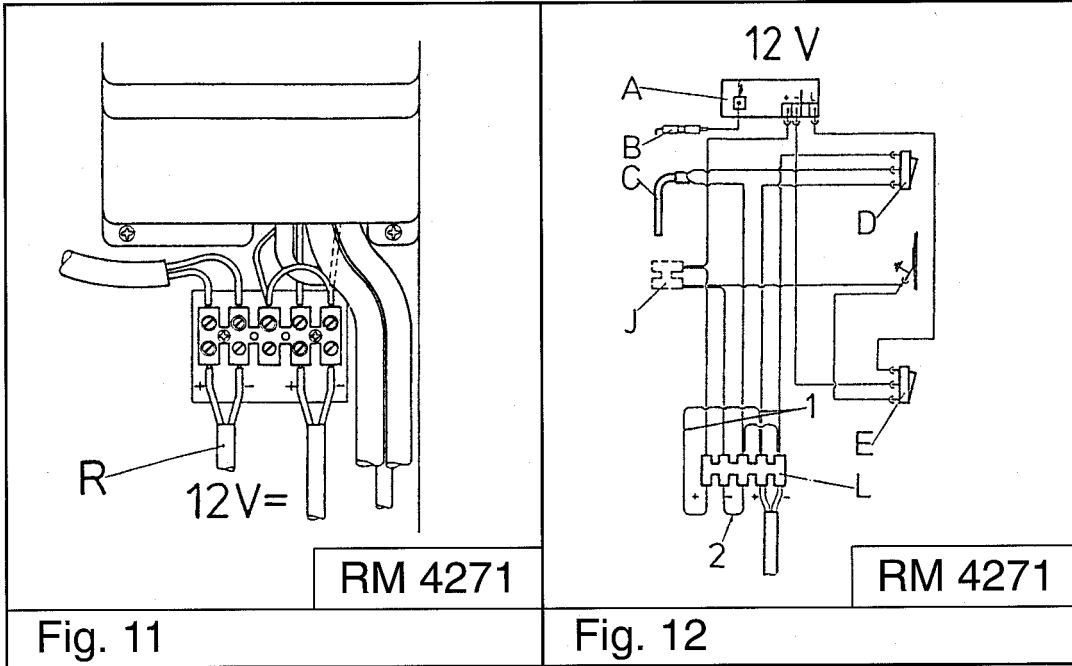



Fig. 10





Electrolux

DECLARATION OF CONFORMITY

according to

Low Voltage Directive 73/23/EEC and
 the Amendment to LVD 90/683/EEC
 EMC Directive 89/336/EEC
 EMC Automotive Directive 72/245/EEC and
 the Amendment 95/54/EC Annex I (Electronic subassembly)
 Gas Directive 90/396/EEC
 CE Marking Directive 93/68/EEC

Type of equipment	Absorption Refrigerator
Brand Name	ELECTROLUX
Type designation	C 40/ 110 (type family)
Manufacturer's (Factory) name	ELECTROLUX Siegen GmbH
address	In der Steinwiese 16, D 57074 Siegen
telephone no	INT+49 - 271 692 0
telefax no	INT+49 - 271 692 304

The following harmonized standards or technical specifications (designations) which comply with good engineering practice in safety matters in force within the EEA have been practiced.

EN 60335-1 (IEC 335-1), EN 60335-2-24 (IEC 335-2-24)	Low Voltage Directive
EN 60555-2, EN 60555-3, EN 50082-1, EN 55014	EMC Directive
PR EN 732, DIN 3370, DIN 30694 T4	Gas Directive

The equipment conforms completely with the above stated harmonized standards or technical specifications.

By signing this document, the undersigned declares as manufacturer, or the manufacturer's authorized representative established within the EEA, that the equipment in question complies with the requirements stated above.

Manufacturer		
Date	Signature	Position
04.03.96		General Manager
	Clarification	
	Gunter Bittner	